

CONSTANT FILL / FIXED SPEED COUPLING

Steel Body Coupling TYPE SF

Specifications:

Rating Table SF:

SF MODEL							
Model	600	750	900	1000	1200	1500	1800
4	1	1.8	3	4	8	15	22
6	2.6	5	9	12	20	40	60
7	4	7.5	13	18	31	60	80
8	5.6	11	19	26	45	80	114
9	10	19	33	45	78	152	197
10	14.4	28	48	66	115	224	290
566	20	40	68	93	161	315	375

Dimension Table: SF:

Fluid Coupling Model SF	ϕA	B	$\Phi d1$ Max	l1	$\Phi d4$ Max	l4	Flex Coupling Model FXC	Dry Wt. Kg	Max Filling Liters
4	375	250	50	80	55	70	II	55	4.8
6	418	267	75	110	90	95	III A	82	7.8
7	470	300	75	110	90	95	III	98	10.0
8	508	310	75	110	90	95	III	106	13.5
9	570	330	110	140	110	110	III	190	18.75
10	620	345	110	140	110	125	IV	205	27

Connected Flexible Coupling:

Flexible Coupling Model	Internal Hub			External Hub			Pad Type Coupling		
	ød1 Max.	l1	L1	ød2 Max.	l2	L2	ød3 Max.	l3	L3
FFX-1	42	67	67	60	75	130	—	—	—
FFX-3	80	92	72	90	110	170	—	—	—
FFX-4	90	102	87	100	120	195	—	—	—
FFX-5	—	—	—	125	150	230	—	—	—
FP-1	—	—	—	—	—	—	100	110	120
FP-2	—	—	—	—	—	—	140	115	167

SF Fluid Coupling Model:

Type SF

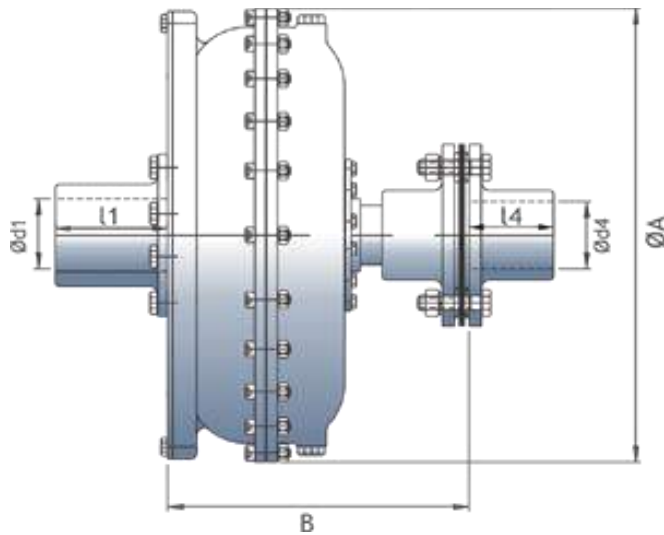

Flexible Coupling:

